

## Basic set up instructions

Now you have received your new bicycle from Tredz, there are just a few steps to do before you are ready to ride your bike.

### TIGHTENING QUILL STYLE STEM & HANDLEBARS

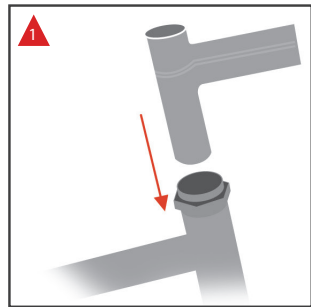

Slot the shaft of the handlebar stem into the hole of the fork's steerer tube.

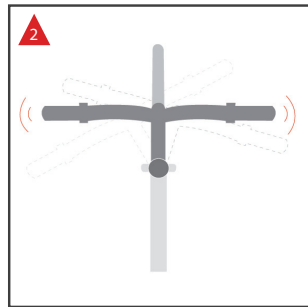

Line up the handlebar\* so that from above, it is at a 90° angle to the front wheel.

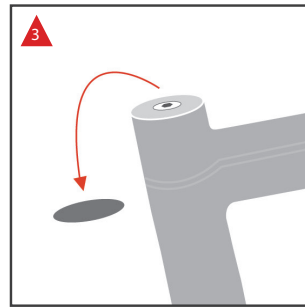

Sometimes there may be a plug in the top of the stem concealing the bolt. In this case pry the plug out carefully with a flat head screwdriver.

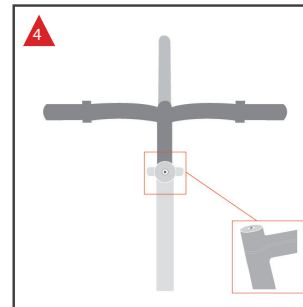

At present the handlebars should be at a 90° angle to the front wheel and the bolt at the top of the stem in sight.

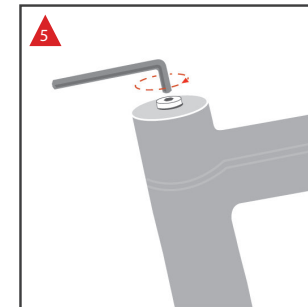

Tighten the bolt with the allen key provided, until resistance is felt. Reattach plug if needed.

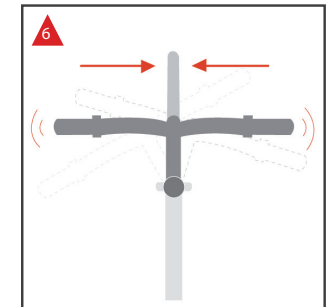

When the bolt is tight, hold the front wheel between your legs, and ensure that the handlebar won't twist easily under the pressure. If there is movement further stem bolt tightening is needed\*\*

### TIGHTENING A THREADLESS HEADSET & HANDLEBARS

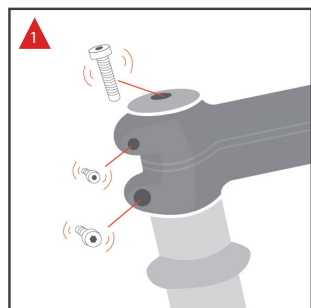

First ensure all stem bolts are in place and are loose.

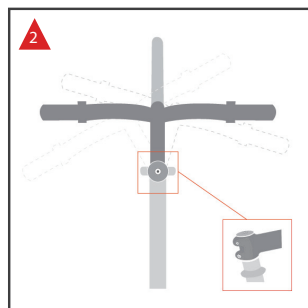

Line up the handlebar\* so that from above, it is at a 90° angle to the front wheel.

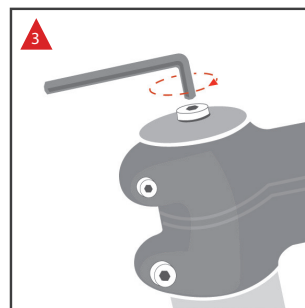

Tighten the headset bolt until pressure is felt using the allen key provided.

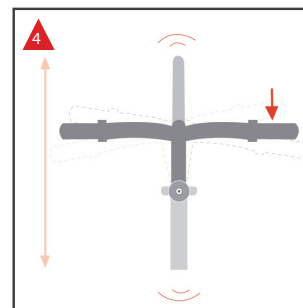

Check the headset for play. This can be done by holding the front brake and vigorously rocking the bike forward and backward.

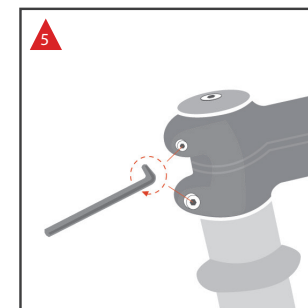

When the headset is tight, check that the handlebars are still 90° to the front wheel and tighten down the stem bolts to secure stem into position.

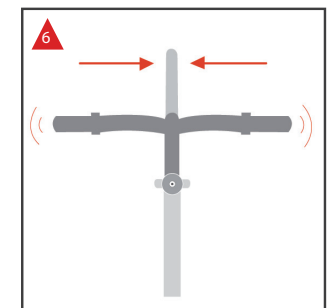

Finally to check the stem is secure, place the front wheel between your legs and twist the handlebars. If there is movement further stem bolt tightening is needed\*\*

**!** \* Ensure the wheel is facing in the right direction. If the bicycle is fitted with a disc brake, ensure the brake disc is located on the opposite side to the cranks and chain. If the bicycle is fitted with cable brakes, the brake unit should be positioned at the front of the fork. \*\* Be careful not to over-tighten as this can cause damage

IF YOU HAVE ANY QUESTIONS ABOUT THIS OR ANY OTHER ASPECT OF YOUR CYCLE THEN PLEASE CONTACT US:

**01792 799508**  
Monday - Friday (9am - 5:30pm)

Or email us at: [sales@tredz.co.uk](mailto:sales@tredz.co.uk)

 **Live help available online**

## Basic set up instructions

Now you have received your new bicycle from Tredz, there are just a few steps to do before you are ready to ride your bike.

PEDAL ASSEMBLY - FAILURE TO FOLLOW INSTRUCTIONS WILL INVALIDATE GUARANTEE

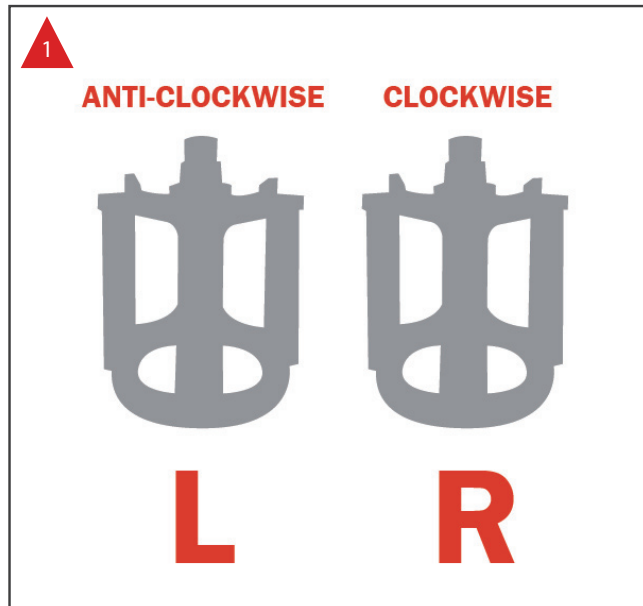

Identify **Left** and **Right** pedals, by letters **R** and **L** stamped on the end of the axle or on the pedal body.

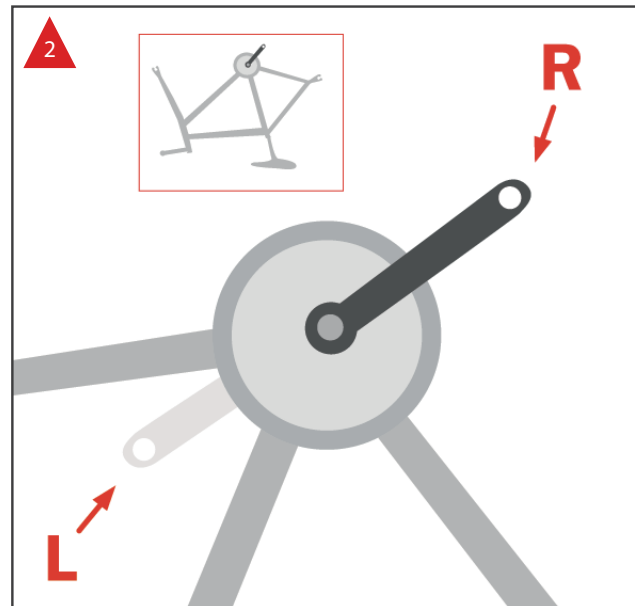

Identify **Left** and **Right** cranks. **Right / Drive side will have the chain and chain rings attached.**

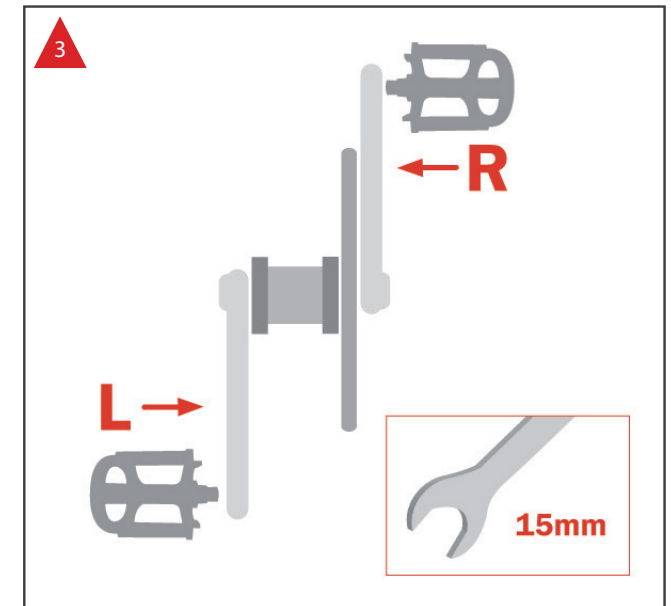

Tighten pedal by hand into correct crank. Then using a 15mm spanner, tighten in correct rotation to the limit of average strength (or to the manufacturer's specified torque, if given).

**RIGHT PEDAL TIGHTENS CLOCKWISE  
LEFT PEDAL TIGHTENS ANTI-CLOCKWISE**

IF YOU HAVE ANY QUESTIONS ABOUT THIS OR ANY OTHER ASPECT OF YOUR CYCLE THEN PLEASE CONTACT US:

**01792 799508**  
Monday - Friday (9am - 5:30pm)

Or email us at: [sales@tredz.co.uk](mailto:sales@tredz.co.uk)

 **Live help** available online

**Tredz Ltd** - Castell Close, Swansea Enterprise Park, Llansamlet, Swansea, SA7 9FH